

DIRECT DIGITAL PORTABLE X-RAY SYSTEM

sri
source-ray, inc.



Source-Ray, Inc.
Model SR-130D

SR-130D

PORTABLE DIGITAL IMAGING SOLUTIONS

The SR-130D Direct Capture Digital Portable X-Ray system was designed for today's demands of general radiography, trauma and bedside care. The SR-130D utilizes Canon Medical System's CXDI-50G large format 14" X 17" x-ray sensor panel.

Large Imaging Area

Convenient 14" x 17" Format



Versatile Positioning

Once in place, the digital detector provides **high resolution digital images** that can be stored on disc or sent to an off-site radiologist for diagnostic clinical evaluation.



Compact Design

The **compact design** allows the SR-130D to be used for a wide range of X-ray applications



Protective Storage

Convenient storage box provides protection for the digital panel and grid adapter when not in use or **during transportation**.



The SR-130D system has an *integrated touch screen computer* with integral keyboard for selecting *Anatomical Programming* or manual selection of x-ray techniques. It also provides the ability to export study lists to PACS systems for clinical history and follow-up exams. The SR-130D is *DICOM 3 compatible*.

Easy Data Entry

Enter patient data using convenient **touch screen** panel

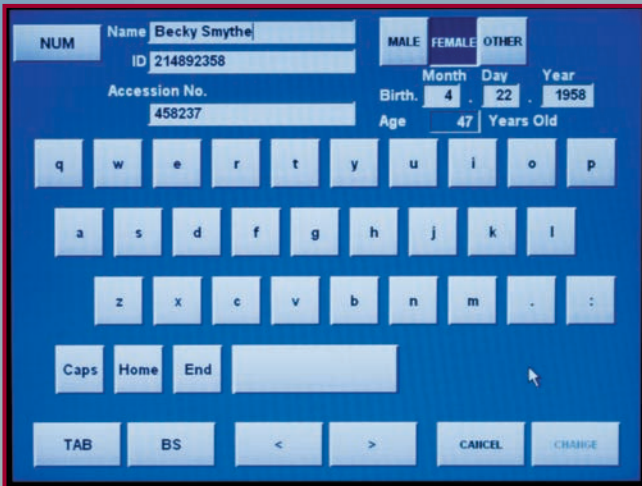

Anatomical Programming

Select **Anatomical Region** of interest. Then **Anatomical View**.



Fast Results

View Image immediately, **Magnify** or **Enhance** image with on-board tools.

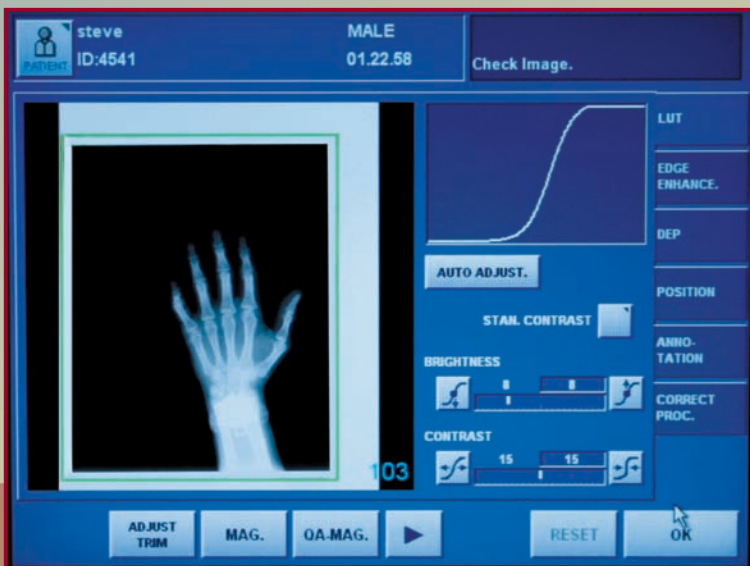

Manual Over-Ride

Over-Ride any pre-programmed technique easily and quickly.

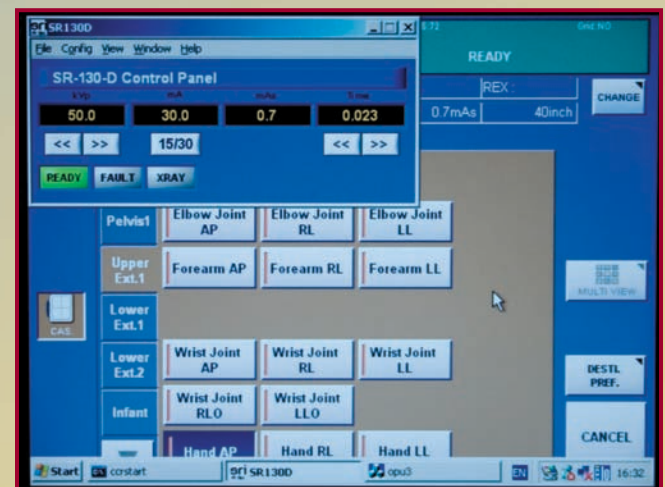

The model SR-130D brings digital radiography directly to the patient. With a portable sensor designed for patient comfort and quick access to images, the SR-130D provides unmatched speed and efficiency for diagnosing even the most critically ill patients.

Digital Radiography

ELECTRICAL SPECIFICATIONS

Generator	HF resonant inverter – 3.0 kW	Computer	RDP Health
Line Voltage	115/230 VAC 50/60 Hz	CPU	P4 2.0 GHZ
kVp Range	40 – 100 kVp, adjustable in 1 kV increments - closed loop regulation	Drive	40 GB
mA Range	Fixed, 15 mA and 30 mA - closed loop regulation	Display	15" TFT (Touch Screen)
mAs Range	0.15 - 120	Ports	10/100 Base T USB
Exposure Time Indicators	0.01 – 4.00 seconds	Digital Panel Method	Canon CXDI Series Scintillator + Amorphous Silicon (a-Si)
Exposure Switch	Detachable two position switch	Sensor	Amorphous Silicon (a-Si) Flat Panel Sensor
X-Ray Tube	Stationary Anode 100 kVp	Grid Application	Attachable (Canon CXDI grid)
Filtration	2.7 mm al minimum	Pixels	Portable 2,208 x 2,688 pixels (5.9 million pixels)
Target Material	Tungsten	Image size	Automatic sizing up to 14 x17 inches
Anode Capacity	30,000 HU Storage	Pixel pitch	160 x 160 microns
Focal Spot	1.0 mm	A/D	14-bit
Target Angle	15°	Grayscale	4,096 (12-bit) grayscale
Collimator	Advantech R72/32-ET	Sensor Unit	(W x L x T) 19.3 x 19.9 x 0.9 inches, 10.6 lbs
Tape Measure	SID Measurement	System Weight	175 lbs / 79 kg
Inclinometer	Angle Measurement		

OPTIONAL EQUIPMENT

Grid Adapter	Attachable (Canon CXDI grid) 8:1, 103 L, 110 cm focus
MDR Express	MDR Express records DICOM images (CD or DVD Format) in their original digital format, so there is no resolution loss. Installs a DICOM viewer application on each disc, allowing for easy image viewing.
Mobile Access	Saves images in DICOM-3 format and Station image encryption (HIPAA). Provides patient demographics to portable unit.
DR Image Viewer (Basic Workstation)	Features pixel-to-pixel display for viewing high-resolution life-size images in addition to multi-study viewing for quick comparisons with other DR exams
DR Image Viewer (Additional Viewing)	Allows software to be loaded on additional remote computers
DR Image Viewer (Stitching Application)	Application for stitching multiple images together

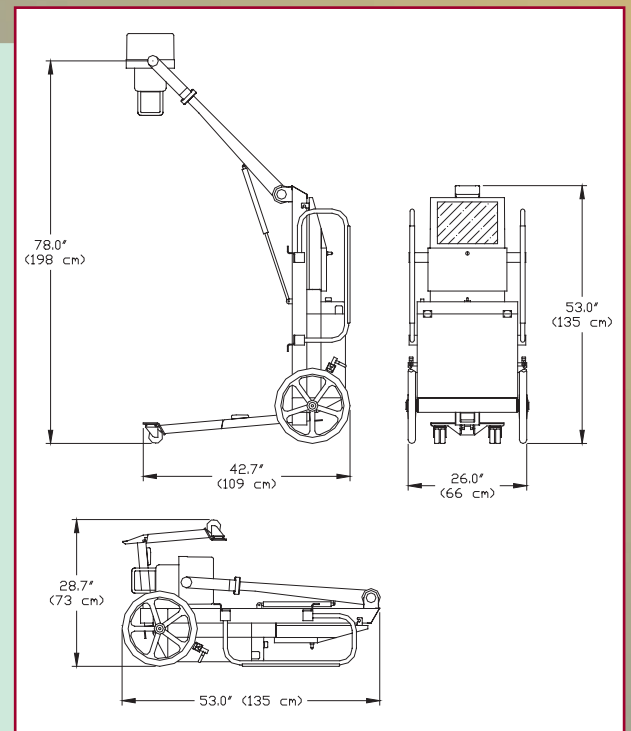

Specifications are subject to change without notice.

Names of companies and/or products appearing in this document are trademarks and /or registered trademarks for their respective companies.

sri
source-ray, inc.

Source-Ray, Inc. • 167 Keyland Court • Bohemia, NY 11716
(631) 244-8200 • Email: sales@sourceray.com • fax (631) 244-7464